

T. A. EDISON.  
PROJECTILE.  
APPLICATION FILED FEB. 12, 1916.

1,300,708.

Patented Apr. 15, 1919.

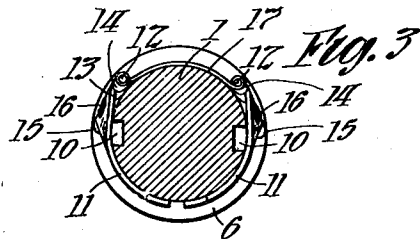
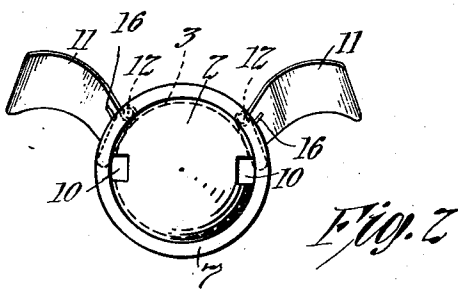
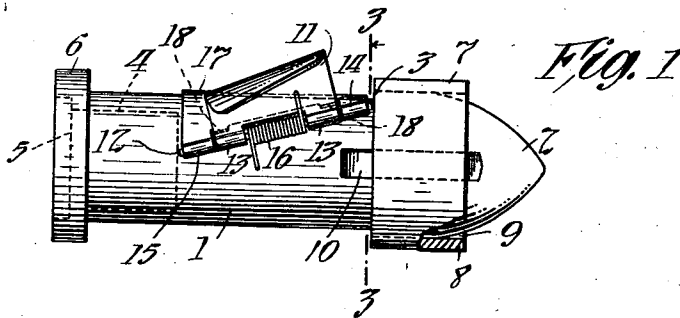

*Witnesses:*  
*Frank Lewis*  
*William A. Hardy*

*Inventor:*  
*Thomas A. Edison*  
*by Dyer and Holden*  
*His Atty.*

# UNITED STATES PATENT OFFICE.

THOMAS A. EDISON, OF LLEWELLYN PARK, WEST ORANGE, NEW JERSEY.

## PROJECTILE.

1,300,708.

Specification of Letters Patent.

Patented Apr. 15, 1919.

Application filed February 12, 1916. Serial No. 77,833.

*To all whom it may concern:*

Be it known that I, THOMAS A. EDISON, a citizen of the United States, and a resident of Llewellyn Park, West Orange, Essex county, New Jersey, have invented certain new and useful Improvements in Projectiles, of which the following is a description.

My invention relates to projectiles and especially to projectiles for use in guns of large caliber, being in some aspects an improvement on the inventions disclosed in my copending applications Serial No. 73868, filed January 24, 1916 and entitled Projectiles, and Serial No. 77,832 filed February 12, 1916, and entitled Projectiles.

The principal object of my invention is to provide an improved type of projectile having means which will cause a lifting or raising force, opposing the action of gravity, to be exerted on the projectile when in flight, to thereby render it possible to obtain with such a projectile a comparatively flat trajectory and a greatly increased range as compared with projectiles heretofore used when discharged under similar conditions.

Another object of my invention is to provide the projectile with stabilizing means in addition to and preferably cooperating with the lifting or raising means above mentioned, for preventing the projectile, when in flight, from rotating about its longitudinal axis and from "hurtling" or turning end over end, to thereby render such lifting or raising means much more effective.

Other objects and features of my invention will be hereinafter more fully described and claimed.

In order that my invention may be more clearly understood, attention is directed to the accompanying drawing forming a part of this specification, and in which:

Figure 1 is a view in side elevation, partly broken away, of a projectile constructed in accordance with my invention, and showing the same substantially in the position it occupies when in flight and with the wings or vanes thereof in operative or open position;

Fig. 2 is an end view of the projectile looking from the right in Fig. 1; and

Fig. 3 is a sectional view taken on the line 3-3 of Fig. 1, showing the wings or vanes in inoperative or closed position.

Referring to the drawing, my improved projectile preferably comprises a main cylindrical body portion 1 and a forward end

portion having a pointed head or "nose" 2. The forward end portion of the projectile has a rear cylindrical portion of slightly greater diameter than the body portion 1, whereby a shoulder 3 is formed on the projectile at the rear end of said forward end portion. The head end portion of the projectile is preferably made heavier than the rear end portion thereof, as by providing the latter with a cylindrical longitudinally extending recess or cavity 4, whereby the projectile has a tendency to travel "head on" in its flight. If the projectile is to be used as a shell, the recess 4 may be filled with any suitable explosive or with an explosive and shot. The recess 4 is preferably closed at its rear end by a suitable member or cap 5 which is preferably flush with the rear end of the projectile. At its rear end the projectile is preferably provided with a suitable collar 6, which may be integral therewith but which is preferably in the form of a copper ring suitably applied and secured to the projectile. The copper ring 6 is preferably slightly greater in diameter than the main bore of the gun for which the projectile is designed, whereby when the projectile is forced through said main bore upon the discharge of the gun, the said ring will be compressed so as to tightly fit the said main bore and will act as a packing to prevent the escape of gases past the projectile. A cylindrical collar 7 adapted to closely fit the main bore of the gun for which the projectile is designed, is suitably formed on or secured to the cylindrical portion of the forward end portion of the projectile with the rear end thereof flush with the shoulder 3. The collar 7 is preferably provided with a cylindrical extension 8 projecting forwardly over the "nose" 2, thereby forming an annular space 9 between the extension 8 and "nose" 2. The projectile is preferably provided beneath the collar 7 with a plurality of straight longitudinally extending open-ended grooves 10 which are equally spaced circumferentially of the projectile. The grooves 10 are preferably parallel to the longitudinal axis of the projectile, and the forward ends thereof preferably communicate with the annular space 9 and terminate in the "nose" 2. The grooves 10 preferably extend a short distance rearwardly beyond the collar 7, such rearwardly extending portions gradually decreasing in depth and

merging in the surface of the cylindrical body portion 1. While the projectile as shown in the drawing is provided with only two grooves 10, it is to be understood that the same may have any number of such grooves. When the projectile is in flight, the air caught or entrapped in the annular space 9 is forced with great velocity through the grooves 10 and coacts with the walls of such grooves to overcome any tendency which the projectile may have to "hurtle" or turn end over end, and also any tendency which the projectile may have to turn or rotate about its longitudinal axis, as described in my copending application Serial No. 77,832 referred to above. The air will also coact with the shoulder formed by the collar 6 on the rear end of the projectile, to prevent tipping of said end and thereby the "hurtling" of the projectile when in flight.

In addition to the stabilizing means above described comprising the collar 7, annular space 9, grooves 10 and collar 6, I also provide the projectile with means preferably in the form of a plurality of wings or vanes 11 normally extending laterally therefrom, which will cause a lifting or raising force, opposing the action of gravity, to be exerted on the projectile when in flight, and thereby render it possible to obtain with such a projectile a comparatively flat trajectory and a greatly increased range. Preferably only two such wings or vanes are employed, and these wings or vanes are preferably pivotally mounted on the cylindrical body portion 1 of the projectile just to the rear of the collar 7 and preferably substantially over the center of gravity of the projectile, by means of a pair of rods 12 to which the wings are respectively secured by lugs 13, the rods 12 being respectively loosely mounted in pairs of lugs 14 and 15 formed on a supporting member or bracket 17 rigidly secured to the said body portion 1. Coiled springs 16 loosely mounted on rods 12 and having their ends bearing against the projectile and the wings 11 respectively, constantly tend to force the wings to operative or open position, as shown in Figs. 1 and 2. The supporting member or bracket 17 is provided with outstanding stops 18 to limit the extent to which the wings open under the action of the springs 16. The pivots of the wings or vanes 11 are preferably symmetrically disposed on either side of and above the longitudinal axis of the projectile, with reference to the normal position of the projectile when in flight, as shown in the drawing. The pivots of the wings or vanes 11 and the wings themselves are preferably inclined away from the longitudinal axis of the projectile toward the head end of the latter as shown in Fig. 1, the wings or vanes being warped so as to lie closely against the cylindrical body portion 1 when turned

about their pivots against the action of springs 16 to folded or closed position, as shown in Fig. 3. At their rear end the grooves 10 preferably respectively terminate beneath the forward end portions of the wings or vanes when the latter are in closed position.

When the wings or vanes 11 are folded or closed, the same lie within the contour of the collar 7, thereby permitting the projectile to be readily inserted in the gun for which it is designed. When the projectile is discharged from the gun, the springs 16 and the air emerging from the rear end of grooves 10 will at once force the vanes to open or operative position, as shown in Figs. 1 and 2. During the flight of the projectile the air will act on the inclined wings 11 to assist the stabilizing means in preventing the projectile from hurtling and rotating about its longitudinal axis, and also to cause a raising or lifting force to be exerted on the projectile.

The results due to providing the projectile with the wings or vanes as described herein may be varied greatly without departing from this invention, by changing the number, size, disposition and inclination of these wings or vanes. The wings may also be so mounted on the projectile that the inclination thereof with respect to the longitudinal axis of the projectile may be varied; and suitable mechanism may be employed, operable by the air or by other means, to automatically increase the inclination of the wings during the flight of the projectile in such a manner as to compensate largely for the decreasing speed of the projectile.

While I have specifically described and shown but one embodiment of my invention, it is to be understood that various changes and modifications in addition to those above mentioned may be made therein without departing from the spirit of the invention and the scope of the appended claims.

Having now described my invention, what I claim and desire to protect by Letters Patent is as follows:—

1. A projectile having a plurality of wings mounted thereon, and a plurality of longitudinally extending open-ended grooves extending forwardly from said wings and respectively terminating at their rear ends beneath the forward end portions of such wings, substantially as described.

2. A projectile provided with a plurality of longitudinally extending open-ended grooves and with a pair of wings or vanes normally extending laterally therefrom, said wings or vanes being symmetrically disposed with respect to the longitudinal axis of the projectile substantially over the center of gravity thereof, substantially as described.

3. A projectile having a reduced forward

end portion or "nose", said projectile having a cylindrical extension projecting forwardly over said "nose" and forming an annular space between said extension and "nose," the projectile being provided with a plurality of longitudinally extending open-ended grooves the forward ends of which communicate with said space, and with a plurality of wings or vanes normally extending laterally therefrom, substantially as described.

4. A projectile having a plurality of wings mounted thereon, and a plurality of longitudinally extending grooves, said grooves respectively terminating at their rear ends beneath said wings, substantially as described.

5. A projectile provided with a plurality of grooves, and a plurality of vanes or wings, said grooves being so arranged that fluid passing therethrough due to the travel or flight of the projectile will be directed beneath said vanes or wings, substantially as described.

6. A projectile provided with a plurality of longitudinally extending grooves and with a plurality of vanes or wings movably mounted thereon, said grooves being so disposed that fluid passing therethrough due to the travel or flight of the projectile as-

sists in opening said vanes or wings, substantially as described.

7. A projectile provided with a plurality of longitudinally extending grooves and with a pair of vanes or wings movably mounted thereon, said vanes or wings being symmetrically disposed with respect to the longitudinal axis of the projectile, and said grooves being so arranged that fluid passing therethrough due to the travel or flight of the projectile assists in opening said vanes or wings, substantially as described.

8. A projectile having a wing mounted thereon, and a longitudinally extending groove, said groove terminating at its rear end beneath said wing, substantially as described.

9. A projectile provided with a groove and with a vane or wing, said groove being so arranged that fluid passing therethrough due to the travel or flight of the projectile will be directed beneath said vane or wing, substantially as described.

This specification signed and witnessed this 5th day of February, 1916.

THOS. A. EDISON.

Witnesses:

WILLIAM A. HARDY,  
FREDERICK BACHMANN.